

TYPE  
CR2400T  
- CR5000T

It's in the air ...

... quality does indeed  
make a difference!



- References*
- Dry air storage
  - Breweries
  - Water works
  - Low temperature applications (+3C --+5C)
  - Curling arena

## TYPE CR2400T - CR5000T

### Description

Desiccant dehumidifiers in the CR-T range consists of four models, designed for room air dehumidification. The chosen proportion between rotor dimension, air capacity and connected load, results in dehumidifiers with very high energy efficiency. This design has considerable advantages, particularly at low temperature and low %RH.

### Features

- Cabinet manufactured in galvanized steel, painted RAL7047
- High capacity, kg/h, at normal temperature and %RH
- Economic operation, in particular at low temperatures and low %RH
- Filter cassettes can be replaced without removal of connected ducting
- Pressure available for external dry air and regeneration air ducts
- Built-in fans for reduced sound level
- Complete dehumidifier, ready for connection to ductwork and power supply at site
- Stepless control of electric heater (controller/SSR relays)
- High performance desiccant rotor of silica gel, washable
- Separate process- and regeneration air flow, 2 fans, efficient gaskets
- Easy access for internal maintenance and service

### Applications

This range of dehumidifiers has a variety of applications, among others:

- Dry air storage in general: Humidity control in unheated storage buildings
- Internal corrosion protection of machinery parts, bridges, etc. with dry air
- Cold stores and freezers: Reduction of ice on evaporators, at doors, on ceilings and on goods
- Protection of electronics and electrical installations
- Production and storage rooms with low %RH in the pharmaceutical and the food industries
- Water works (including open top filters)
- Ice rinks

The company policy of making quality products has resulted in dehumidifiers characterized by high reliability, low maintenance costs, maintainability and high capacity. Furthermore, these adsorption dehumidifiers are characterized by high capacity at low temperatures and additional room heating is normally not necessary.

### Controls

All Cotes humidity controls, DR10, DA20, DH24, DCC, can be used for the CR dehumidifiers. The choice depends on the degree of accuracy needed and external user information.

## Technical data

All data are valid for nominal air flows.

Deeper drying can be achieved with reduced process air flow.

Type	Dry air nominal m <sup>3</sup> /h	Reg. air Nominal m <sup>3</sup> /h	Voltage/ Phases	Connected load kW	Reg. air Heater kW	External Fuses A	External pressure Process air Pa	External pressure Reg. air Pa	Capacity at 20°C, 60 %RH Kg/h
CR2400T	2400	520	400/3Ph+PE	19,9	16,6	35	400	400	12,7
CR3200T	3200	720	400/3Ph+PE	25,5	22,2	50	400	400	16,5
CR3800T	3800	850	400/3Ph+PE	31,8	27,7	63	600	350	19,5
CR5000T	5000	1050	400/3Ph+PE	37,8	33,3	63	500	600	24,6

## Dimensions & weight

Type	L mm	W mm	H mm	Process air inlet A mm	Dry air outlet B mm	Reg. air inlet C mm	Reg. air outlet D mm	Weight kg
CR2400T	1927	1000	1352	800 x 600	256 x 361	Ø250	Ø200	460
CR3200T	1927	1000	1352	800 x 600	256 x 361	Ø250	Ø200	460
CR3800T	1927	1000	1352	800 x 600	256 x 361	Ø250	Ø200	495
CR5000T	1927	1000	1352	800 x 600	256 x 361	Ø250	Ø200	495

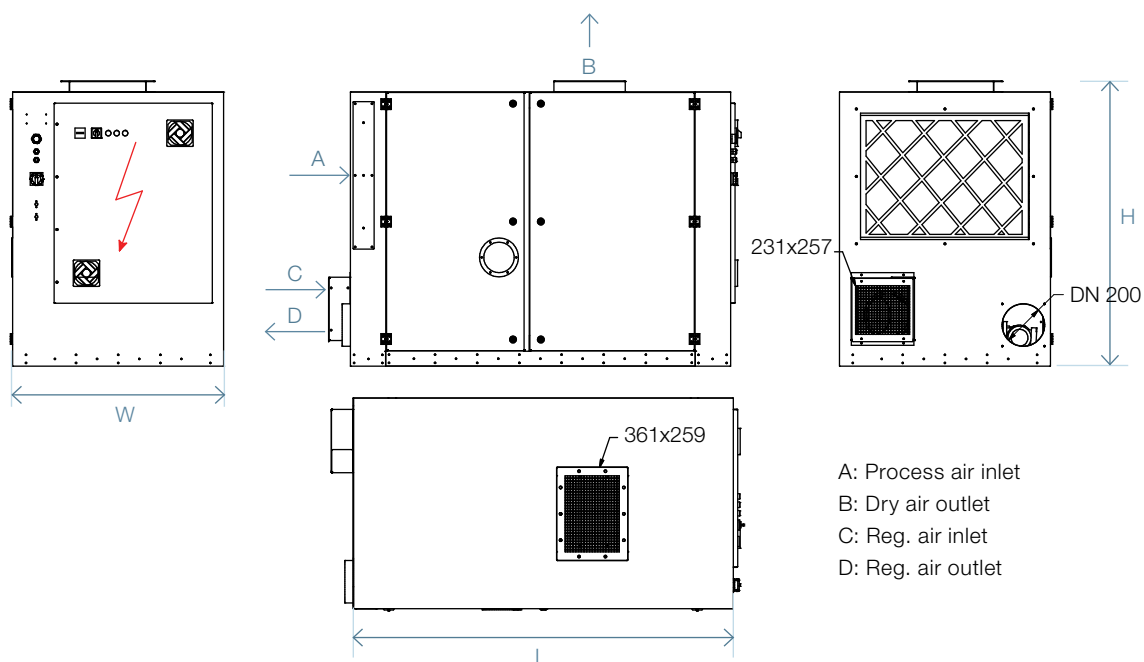

Distributor